

TZ6806S

Electric Toy DC Motor Drive Circuit

Features

- H bridge driver of internal PMOS/NMOS power switches;
- Can realize 4 functions (forward、backward、stop、brake) of load motor;
- Low standby current (typ.0.1uA);
- Low static operational current (typ.300uA, VCC=3V);
- Wide voltage operational range (1.8V—7.0V);
- Low output impedance, continuous current 0.6A, peak current 1.5A output capability;
- On-chip thermal shut down (TSD) with hysteresis

Descriptions

TZ6806S is an integrated circuit driven by a single channel toy DC motor which is designed for low-voltage operated system. It has H bridge driver and uses the PMOS and NMOS power transistors with low output resistance. Low on-resistance ensures the circuit to consume lower power in operating at a continuous current, and ensures the circuit to operate stably for a long time.

TZ6806S has on-chip temperature protection function. When load motor with low internal resistance is in locked rotor or output is short-circuit, TZ6806S output current will increase momentarily, power dissipation of the circuit will go up sharply, and the chip temperature will soar. But, when the chip temperature exceeds a maximum temperature point (typically 150°) set by internal temperature protection circuit, the internal circuit will switch off the on-chip power switching transistor of TZ6806S, and switch off load current, preventing potential safety hazards such as fuming, igniting, etc. Of plastic package caused by over temperature. Only after having confirmed that the circuit has returned to safety temperature, can the on-chip temperature hysteresis circuit be allowed to re-control the circuit.

Typical applications

- Toy motor drive with 2-4 batteries
- Electronic toy robot

Ordering guide

Product model	package	Operational temperature
TZ6806S	8 - SOP	-20°C ~ 85°C

PIN CONFIGURATION

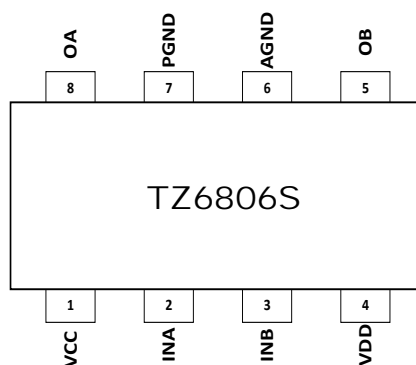

PIN DESCRIPTIONS

Pin NO.	Mnemonic	Input/output	Pin Function Description
1	VCC	-	Power supply of logic control circuit
2	INA	I	Forward rotation logic input
3	INB	I	Backward rotation logic input
4	VDD	-	Power supply
5	OB	O	Backward rotation output
6	AGND	-	Ground of logic control circuit
7	PGND	-	Ground of output power transistor
8	OA	O	Forward rotation output

FUNCTION BLOCK DIAGRAM

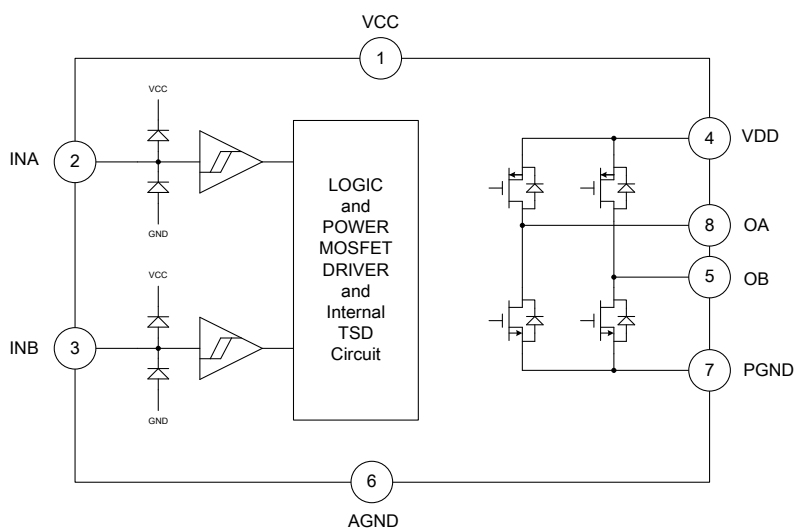

Note: TZ6806S pin number

Functional description

Logic truth table

INA	INB	OA	OB	Function
L	L	Z	Z	Standby (stop)
H	L	H	L	Forward rotation
L	H	L	H	Backward rotation

H	H	L	L	Brake
---	---	---	---	-------

Typical waveform

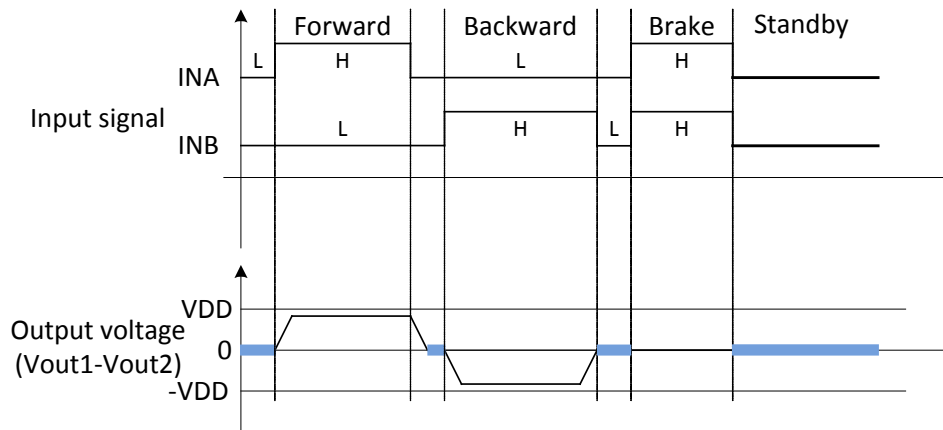

Absolute maximum ratings (T_A=25°C)

Parameter	Symbol	Value	Unit
Maximum logic and control supply voltage	VCC(MAX)	7.0	V
Maximum output supply voltage	VDD(MAX)	7.0	V
Maximum external output voltage	VOUT(MAX)	VDD	V
Maximum external input voltage	VIN(MAX)	VCC	V
Peak output current/channel	IOUT(PEAK)	2.0	A
Maximum power dissipation	SOP8	0.67	W
Junction-to-ambient thermal resistance θ _{JA}	SOP8	184	°C/W
Operational temperature range	T _{opr}	-20~+85	°C
Junction temperature	T _J	150	°C
Storage temperature	T _{stg}	-55~150	°C
Welding temperature	T _{LED}	260°C, 10 Sec	

Notes: (1). Maximum power dissipation at different ambient can be obtained from the following formula

$$P_D = (T_J - T_A) / \theta_{JA}$$

Where T_J is junction temperature with the circuit working, and T_A is the ambient temperature with the circuit working. Calculation of thermal impedance of package is as per ESD 51-7.

(2). Method of calculation of circuit power dissipation

$$P = I * R$$

Where P is circuit power dissipation, I is continuous output current, and R is circuit output on-resistance. Circuit power dissipation P must be smaller than maximum power di ssipation P_D.

Recommended operational conditions (T_A=25°C)

Parameters	Symbol	Min	Typ	Max	Unit
Logic and control supply voltage	VCC	1.8		5	V
Maximum output supply voltage	VDD	1.8		6.5	V
Continuous output current/channel	I _{out}		±0.6		A

Note: Logic control power supply VCC and power supply VDD are fully separate internally, and can supply electricity separately.

Electrical characteristics

($T_A=25^{\circ}\text{C}$, $V_{CC}=3\text{V}$, $V_{DD}=3\text{V}$ unless otherwise stated)

Parameter	Symbol	Conditions	Min	Typ	Max	Unit
VCC standby current	ICCST	INA=INB= L	--	0	10	μA
VDD standby current	IVDDST	VDD=VCC=6V	--	0	10	μA
VCC static supply current	ICC	INA=H, INB=L or INA=L, INB=H or INA=H, INB=H	--	0.3	1	mA
VDD static supply current	IVDD	INA=H, INB=L or INA=L, INB=H or INA=H, INB=H	--	0.1	1	mA
Input high level	VINH		0.8VCC	--	--	V
Input low level	VINL		--	--	0.2VCC	V
Output resistance	RON	$I_O=\pm 200\text{mA}$	--	0.8	1.1	Ω
Spark-killing diode leakage current	IDLEAK		--	--	100	μA
Spark-killing diode voltage	VD	$I_{OUT}=400\text{mA}$	--	1	1.2	V
Protection temperature	TSD		--	150	--	$^{\circ}\text{C}$
TSD hysteresis	TSDH		--	25	--	$^{\circ}\text{C}$

Application information

1. Thermal shut down (TSD)

When junction temperature normally reaches 150°C , switch off all outputs of the circuit. The reason for this is to prevent burnout of circuit due to over-high junction temperature. TSD has hysteresis of about 25°C .

Schematic diagram of typical application circuits

1. Application reference of 2-battery operated remote control toy car

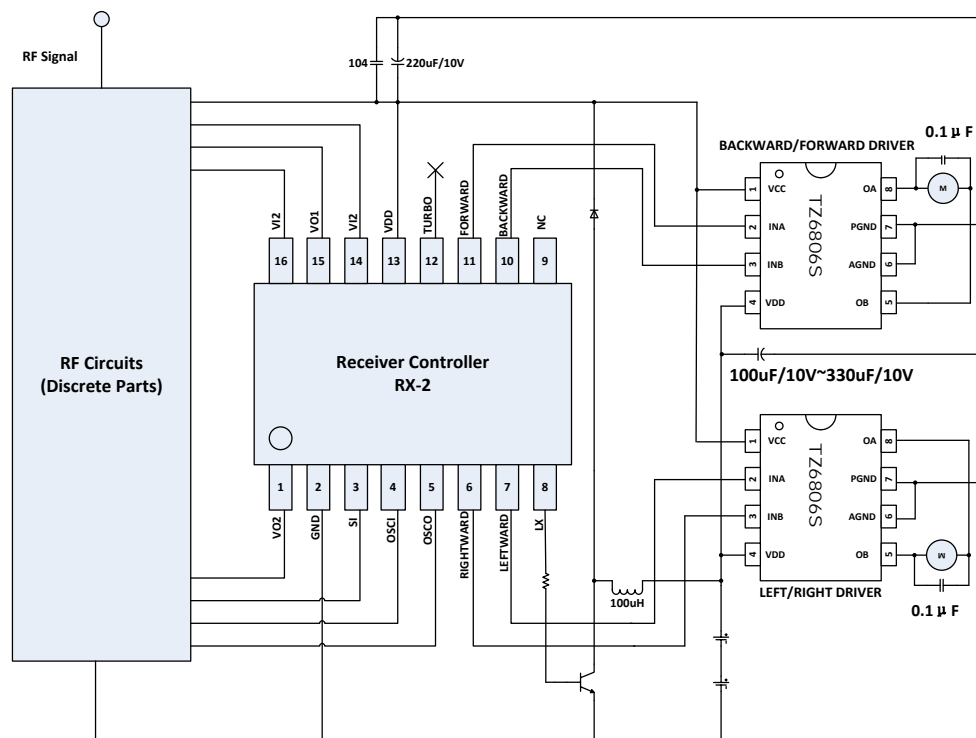

Fig. 1 Schematic diagram of application circuit for 2-battery operated remote control toy car

As shown in Fig.1, the schematic diagram of application circuit for 2-battery operated remote control toy car uses 2 TZ6806S circuits, which are used to drive the forward-and-backward steering motor and the right-and-left steering

motor, respectively. Under normal conditions, RX2 power supply VDD utilizes voltage enhancement design in order to ensure that RX2 obtains a stable power supply when the battery voltage decreases. RX2 power supply terminal (VDD) will need connecting with an electrolytic capacitor of 220uF/10V relative to ground and a ceramic capacitor 104.

Notice of power supply connection:

1. TZ6806S logic power supply VCC must be connected to controller chip (RX2) VDD.
2. TZ6806S power supply VDD must be connected directly to battery anode.
3. TZ6806S logic ground and power ground are connected directly together first, and then are connected to RX2

GND.

Notice of model selection and using TZ6806S:

1. For front wheel steering, it is recommended to use TZ6806SS.
2. If front-wheel driving current does not exceed 1.5A, it is recommended to select TZ6806S.
3. If front-wheel driving current exceeds 1.5A, it is recommended to select TZ6808S.
4. TZ6806S VDD and GND need adding an electrolytic capacitor that is as much close to 2 chips as possible.

Recommended parameters are 100uF/10V—330uF/10V. Select the concrete parameters reasonably according to practical use.

2. Application reference of 3-4 battery operated remote control toy car

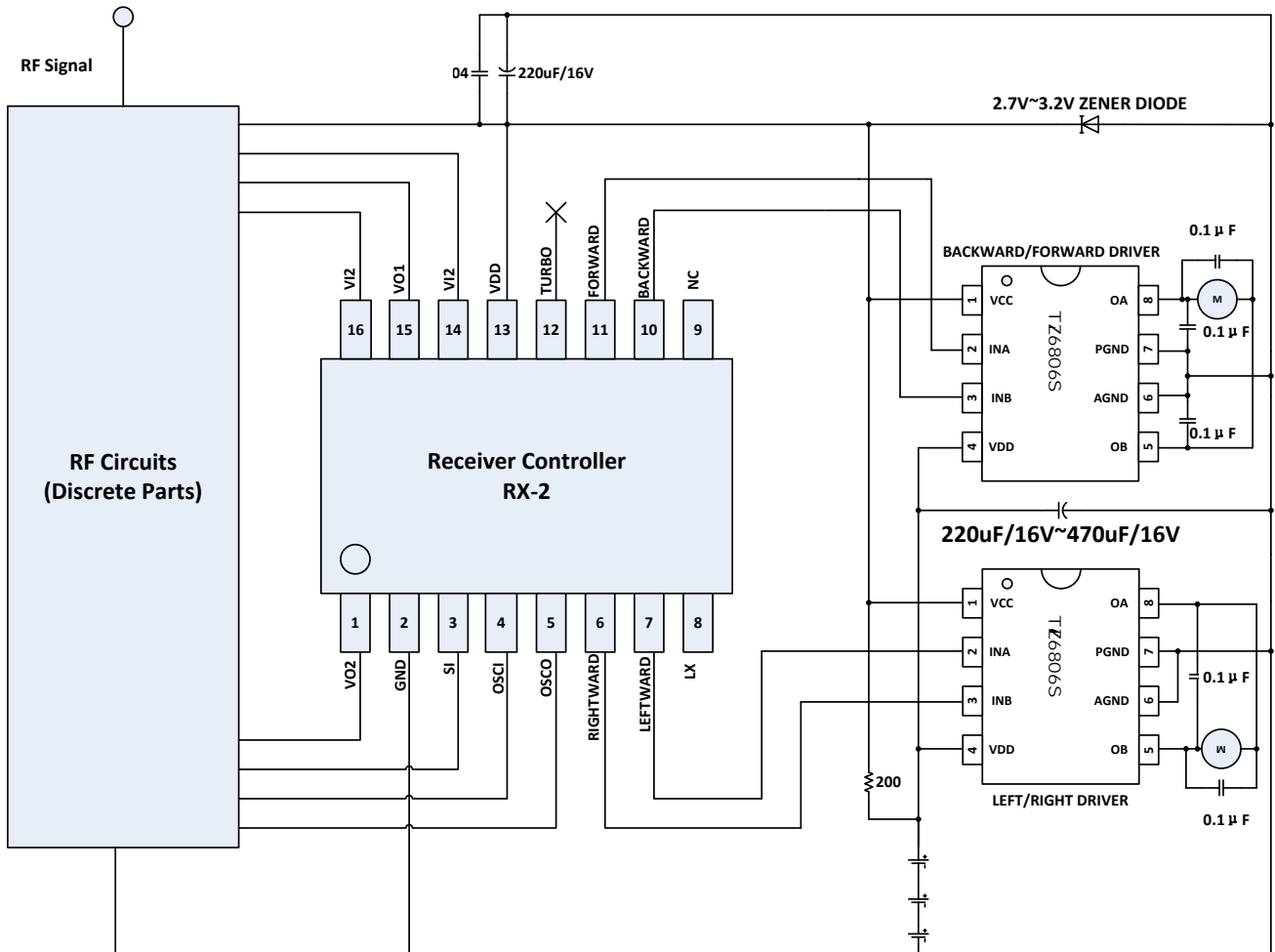

Fig. 2 Schematic diagram of application circuit for 4-battery operated remote control toy car

As shown in Fig.2, the schematic diagram of application circuit for 2-battery operated remote control toy car uses 2 TZ6806S circuits, which are used to drive the forward-and-backward steering motor and the right-and-left steering motor, respectively. Under normal conditions, RX2 power supply VDD utilizes voltage stabilizing diode design to make sure that the circuit operates at safety voltage. In order for RX2 to obtain a stable power supply, RX2 power supply

terminal (VDD) will need connecting with an electrolytic capacitor of 220uF/16V relative to ground and a ceramic capacitor 104. For schematic diagram of application circuit for 3-battery operated remote control toy car, please see schematic diagram of application circuit for 4-battery operated remote control toy car.

Notice of power supply connection:

1. TZ6806S logic power supply VCC must be connected to controller chip (RX2) VDD.
2. TZ6806S power supply VDD must be connected directly to battery anode.
3. TZ6806S logic ground and power ground are connected directly together at the chip first, and then are connected to RX2 GND.

Notice of model selection and using TZ6806S:

1. For front wheel steering, it is recommended to use TZ6806S.
2. If front-wheel driving current does not exceed 1.5A, it is recommended to select TZ6806S.
3. If front-wheel driving current exceeds 1.5A, it is recommended to select TZ6808S.
4. TZ6806S VDD and GND need adding an electrolytic capacitor that is as much close to 2 chips as possible.

Recommended parameters are 100uF/16V-470uF/16V. Select the concrete parameters reasonably according to practical use.

5. In use, the rear wheel motor easily generates larger peak voltage. To prevent chip damage, it is recommended that capacitor 104 relative to ground should be connected to each of nearest possible output terminals of TZ6806S chip for rear wheel motor steering respectively.

6. Current of front wheel steering motor is lower, and peak voltage generated by front wheel steering motor is lower than that by rear wheel steering motor. Due to higher supply voltage, it is still possible to cause the circuit to be damaged. It is suggested to connect capacitor 104 either between output terminals OA and OB, or as shown in Fig. 2.

7. In the case of 3-battery, determine if it is needed to connect capacitor for front wheel steering motor in light of actual conditions. For rear wheel steering, however, it is recommended to connect as shown in Fig. 2.

Schematic diagram for remote controlled toy car LED indicator connection

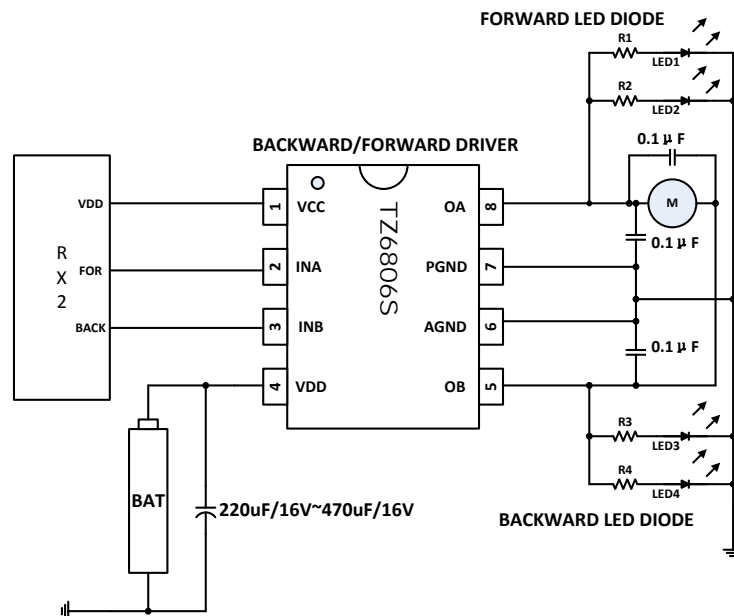

Fig. 3 Schematic diagram for remote controlled toy car LED indicator connection

Fig. 3 shows the schematic diagram for TZ6806S remote controlled toy car LED indicator connection in forward, backward or left, and right turn. In Fig. 3, R1, R2, R3 and R4 are current-limiting resistors. Select a suitable

resistance as the case may be.

As shown in Fig. 3, when the command “forward” is effective, port OA outputs high level but port OB outputs low level. At this time, LED1 and LED2 light up; and vice versa. This characteristic can be used to trigger the remote controlled toy car forward and backward LED indicators. The connection diagram in Fig.3 applies to trigger turn indicator as well.

Special note: it is not recommended that customers use the method of LED indicator’s negative electrode connecting with TZ6806S output and LED indicator’s positive electrode connecting with current-limiting resistor to power supply.

Important notes:

- 1. Foregoing recommended circuits and specifications are applicable only for ordinary remote control toy cars. For other toys and motor operated units, please use TZ6806S as the case may be.**
- 2. Pins of TZ6806S input port cannot be open.**
- 3. Continuous current driving capability will be influenced by factors such as package type, VDD, VCC, chip difference, environment, so specifications given in the datasheet are for reference only. Certain margins should be allowed for in practical applications.**
- 4. TZ6806S is designed and fabricated in MOS process technology, and is sensitive to static. It is necessary to prevent ESD (electro-static discharge) in the course of packaging, transportation, production, etc.**

Outline dimensions of package

SOP8:

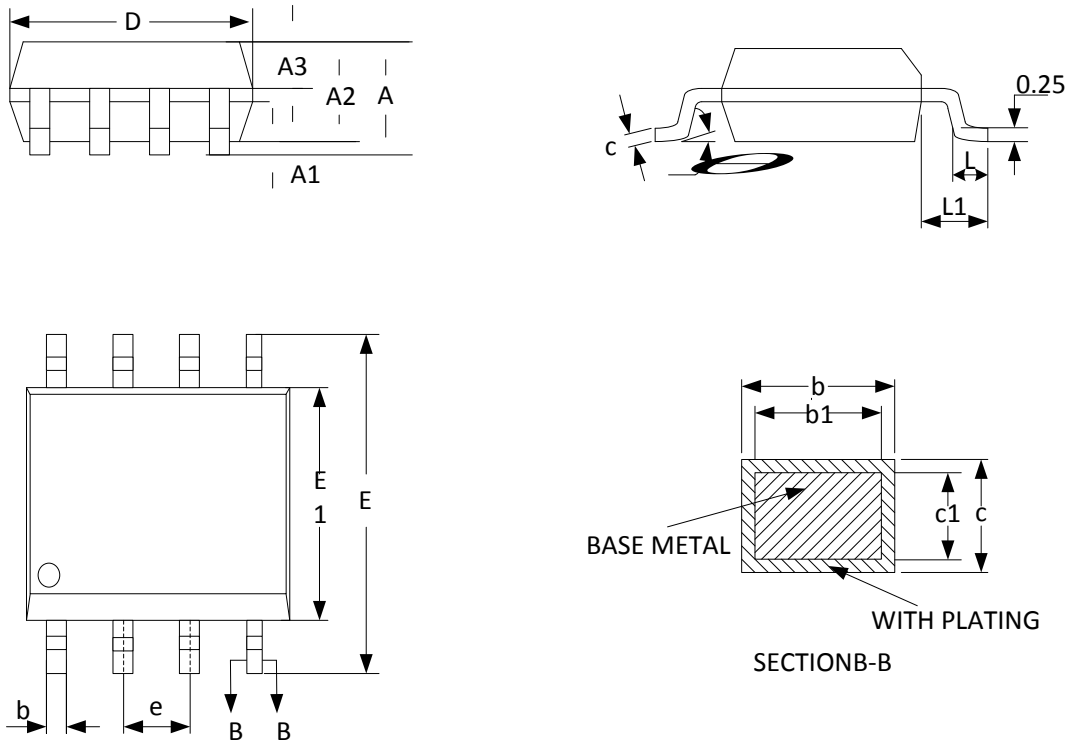

SYMBOL	MILLIMETER		
	MIN	NOM	MAX
A	--	--	1.77
A1	0.08	0.18	0.28
A2	1.20	1.40	1.60
A3	0.55	0.65	0.75
b	0.39	--	0.48
b1	0.38	0.41	0.43
c	0.21	--	0.26
c1	0.19	0.20	0.21
D	4.70	4.90	5.10
E	5.80	6.00	6.20
E1	3.70	3.90	4.10
e	1.27BSC		
L	0.50	0.65	0.80
L1	1.05BSC		
θ	0	--	8°

Version history

Rev1.0 Initial version

Rev1.1 ESD Prevention class and notes were added, and schematic diagram of radio controlled electric plane tail motor drive application was added as well.

Rev1.2 The schematic diagram for TZ6806S remote controlled toy car LED indicator connection in forward, backward or left, and right turn was added.

Rev1.21 Absolute maximum ratings VCC (MAX), VDD (MAX) changed to 6.8V. Recommended operational conditions VDD max value changed to 6.5V.