

MX215D/MX215S

Low Voltage/Low resistance 2-CH DC Motor Driver

Features

- Two channel H-bridge drivers with build in PMOS and NMOS power transistors
- Four functions for each channel - Forward/Reverse/Stop/Brake functions
- Low stand-by current (typ.0.1uA)
- Wide supply voltage (VM=1.8V ~ 7V) suitable for Battery operated applications
- 3.3V and 5V micro-controller interface
- Low output resistance (upper and lower total : typ. 0.7Ω@1A)
- Built-in a thermal shutdown(TSD) function with hysteresis
- Temperature independent internal voltage reference

Description

The MX215D/MX215S is a monolithic two channel dc motor drive IC designed for low voltage operated systems. It has dual H-bridge drivers, using PMOS and NMOS power transistors with a low output resistance. Power packages with heat sinks ensure high continuous output current. The high current and low output resistance make this device suitable for dc motor applications such as toy cars. It has also a built-in thermal shutdown protection circuit with hysteresis.

Typical Application

- General purpose dc motor driver
- Electronic toys - robots
- Digital still camera(DSC) and film camera
- Home appliances and office equipment
- Precision instruments

Ordering information

Device	Package	Operating Temp.
MX215D	16 - DIP	-20°C ~ 75°C
MX215S	14 - SOP	-20°C ~ 75°C

Pin Assignments

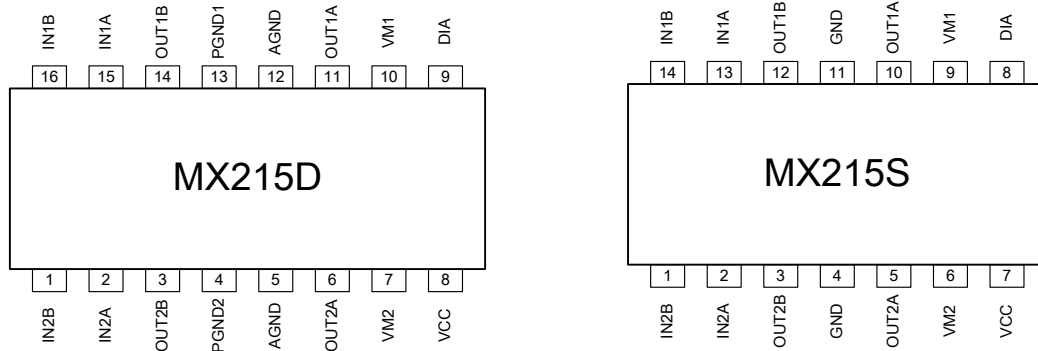

Pin Definitions

Pin Number	Pin Name	I/O	Pin Function Description
1(1)	IN2B	I	Reverse logic input for channel B
2(2)	IN2A	I	Forward logic input for channel B
3(3)	OUT2B	O	Output2 of channel B
4	PGND2	-	Ground
5(4)	AGND	-	Ground
6(5)	OUT2A	O	Output1 of channel B
7(6)	VM2	-	Supply voltage for channel B output
8(7)	VCC	-	Logic and control circuit supply voltage
9(8)	DIA	O	Cathode of OUT1A upper diode
10(9)	VM1	-	Supply voltage for channel A output
11(10)	OUT1A	O	Output1 of channel A
12(11)	AGND	-	Ground
13	PGND1	-	Ground
14(12)	OUT1B	O	Output2 of channel A
15(13)	IN1A	I	Forward logic input for channel A
16(14)	IN1B	I	Reverse logic input for channel A

Note: () MX215S-14 - SOP

Internal Block Diagram

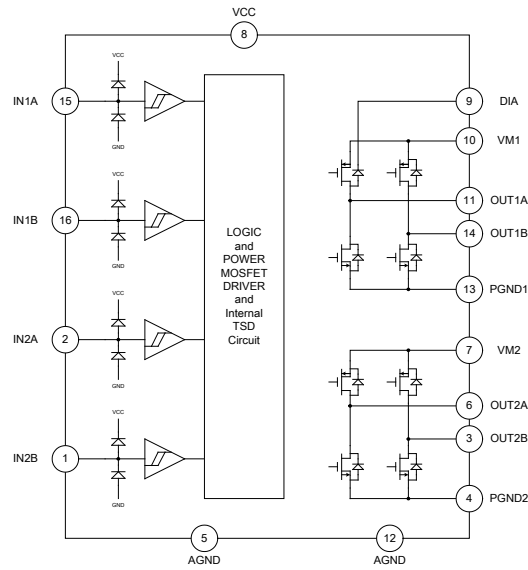

Note: MX215D pin number

Function Descriptions

Logical Truth Table

Channel A

IN1A	IN1B	OUT1A	OUT1B	Function
L	L	Z	Z	Stand-by(Stop)
H	L	H	L	Forward
L	H	L	H	Reverse
H	H	L	L	Brake

Channel B

IN2A	IN2B	OUT2A	OUT2B	Function
L	L	Z	Z	Stand-by(Stop)
H	L	H	L	Forward
L	H	L	H	Reverse
H	H	L	L	Brake

Z: high-impedance

Time Domain Waveforms

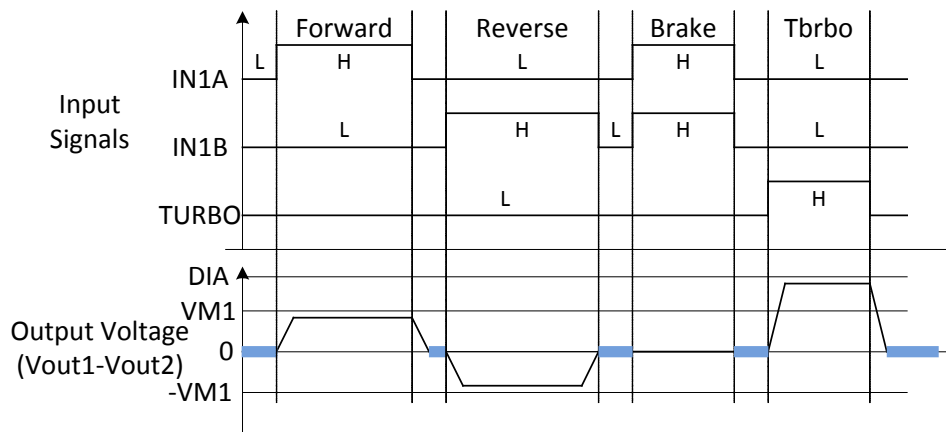

Absolute Maximum Rating (Ta = 25°C)

Parameter	Symbol	Value	Unit
Maximum logic and control supply voltage	VCC(MAX)	6.5	V
Maximum output supply voltage	VM(MAX)	7	V
Maximum output applied voltage	VOUT(MAX)	VM	V
Maximum applied input voltage	VIN(MAX)	VCC	V
Maximum DIA voltage	VIN(MAX)	8	V
Peak output current per channel	IOUT(PEAK)	2.5	A

Recommended Operating Conditions (Ta = 25°C)

Parameter	Symbol	Min.	Typ.	Max	Unit
Logic and control supply voltage	VCC	2.2		6	V
Maximum output supply voltage	VM	1.8		6.5	V
DIA voltage	VDIA	VM		VM+3	V
Continue output current per channel (DIP/SOP)	Iout		±1.5/ ±1		A

Note1: you must connect a capacitor (at least 100uF/16V) to VM when driving a motor.

Note2:the maximum voltage of VM is 6.5V which is equal to 4 dry battery.

Electrical Characteristics

(Ta=25°C, VCC=3V, VM1=VM2=3V, R_{L1}=R_{L2}=15Ω, unless otherwise specified)

Parameter	Symbol	Conditions	Min.	Typ.	Max	Unit
VCC stand-by current	ICCST	IN1A=IN1B=IN2A=IN2B=L	--	0	10	uA
VM stand-by current	IVMST		--	0	10	uA
VCC supply current	ICC	INxA=H, INxB=L or INxA=L, INxB=H or INxA=H, INxB=H	--	0.3	1	mA
VM supply current	IVM	INxA=H, INxB=L or INxA=L, INxB=H or INxA=H, INxB=H with output pins open	--	0.1	5	mA
Input high level voltage	VINH		2.0	--	--	V
Input low level voltage	VINL		--	--	0.8	
Input current	IIN	VIN=3V per each input pin	--	5	20	uA
Pull-down resistance	RIN		--	1.5	--	MΩ
Output resistance	RON	IO=±200mA	--	1.0	1.6	Ω
Spark-killing diode leakage current	IDLEAK	VCC=5V,VM1=VM2=9V	--	--	100	uA
Spark-killing diode voltage drop	VD	IOUT=400mA	--	--	1.7	V
Protection temperature	TSD		--	150	--	°C
TSD hysteresis	TSDH		--	10	--	°C

Application Information

1. Thermal Shutdown (TSD)

Thermal Shutdown Circuit turns OFF all outputs when the junction temperature typically reaches 150°C. It is intended to protect the device from failures due to excessive junction temperature. The Thermal Shutdown has the hysteresis of 10°C approximately.

Typical Application Circuits

1. Application reference 1

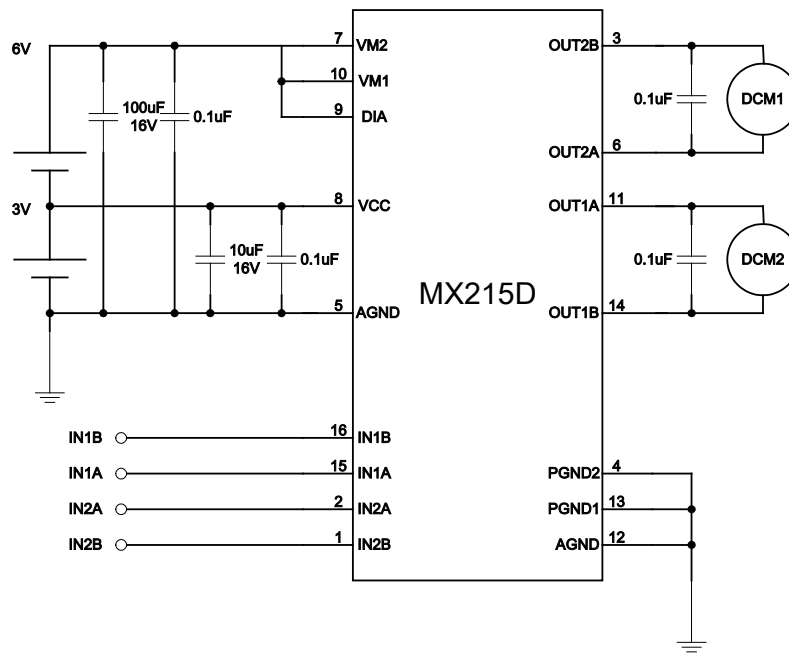

FIG1. DIP16 package of MX215 for typical application

2. Application reference 2

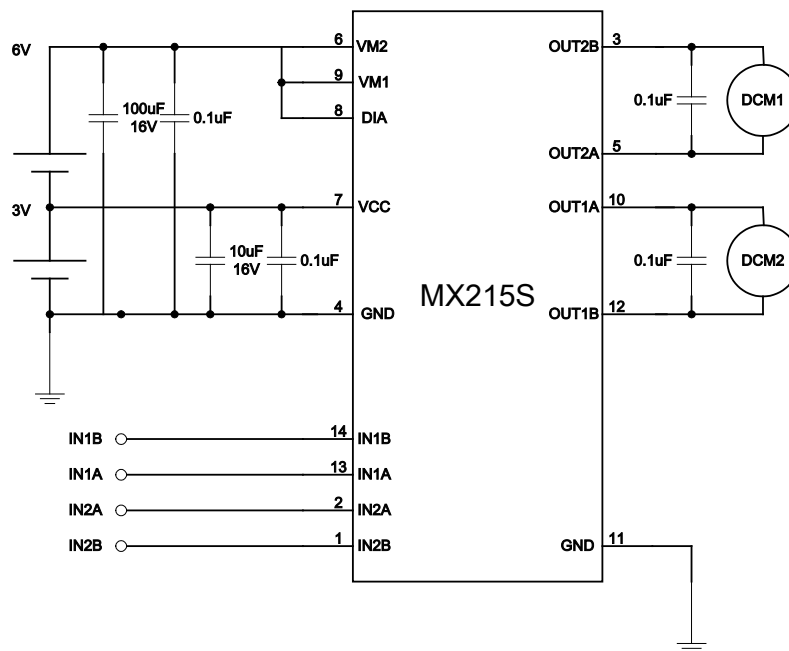

FIG2.SOP14 package of MX215 for typical application

Revision History

Version	Date	Revision Description
1.0	2010/01/15	Initial version
1.1	2010/01/15	